

RF MMIC Innovator

www.berex.com

[CLASSIFICATION] APPLICATION NOTE

[DATE] 2011.04

[REVISION No.] REV.A

[MEASURING INSTRUMENTS]

- NA_AGILENT 8753ES

- SA_AGILENT E4404B

- SG_AGILENT 4438C

- SG_IFR 3416

High Power Amplifier BT331

Application Note



Contents

RF MMIC INNOVATOR	WWW.BEREX.COM	1
1. 836MHZ APPLICATION		3
1.1 836MHZ TEST RESULT(S-PARAMETER, OIP3, P1, NF)		4
2. 836MHZ (RESISTER INSERTION) APPLICATION		5
2.1 836MHZ (RESISTER INSERTION) TEST RESULT(S-PARAMETER, OIP3, P1, NF)		6
3. CDMA(824~894MHZ) APPLICATION		7
3.1 CDMA(824~894MHZ) TEST RESULT(S-PARAMETER, OIP3, P1, NF)		8
3.2 CDMA(824~894MHZ) TEST RESULT(ACPR)		9
4. 900MHZ (RESISTER INSERTION) APPLICATION		10
4.1 900MHZ (RESISTER INSERTION) TEST RESULT(S-PARAMETER, OIP3, P1, NF)		11
5. WCDMA(920~960MHZ) APPLICATION		12
5.1 WCDMA(920~960MHZ) TEST RESULT(S-PARAMETER, OIP3, P1, NF)		13
5.2 WCDMA(920~960MHZ) TEST RESULT(ACLR)		14
6. PCS(1840~1870MHZ) APPLICATION		15
6.1 PCS(1840~1870MHZ) TEST RESULT(S-PARAMETER, OIP3, P1, NF)		16
6.2 PCS(1840~1870MHZ) TEST RESULT(ACPR)		17
7. WCDMA(2110~2170MHZ) APPLICATION		18
7.1 WCDMA(2110~2170MHZ) TEST RESULT(S-PARAMETER, OIP3, P1, NF)		19
7.2 WCDMA(2110~2170MHZ) TEST RESULT(ACLR)		20

0---END---0

1. BT331 _ 836MHz Application Note

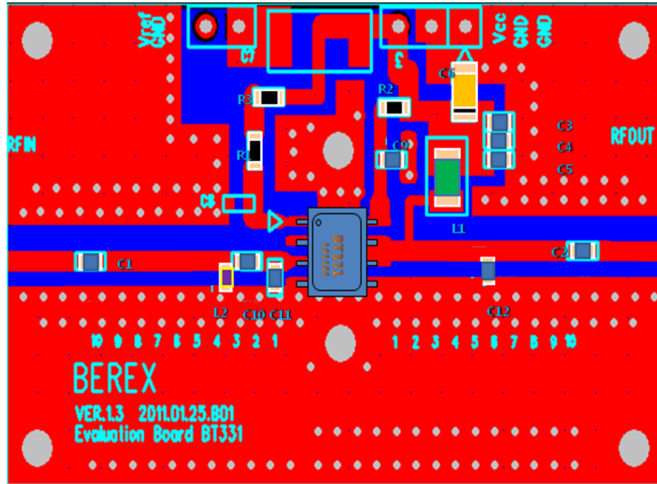

Ref. Des.	Description/ Part Number	Values	Tolerance
C1	1608 CAP	100pF	±5%
C2	1608 CAP	100pF	±5%
C3	1608 CAP	100pF	±5%
C4	1608 CAP	1000pF	±5%
C5	1608 CAP	1uF	±5%
C6	3216 Tantal	10uF	±20%
C7		DNP	
C8		DNP	
C9	1608 CAP	1pF	±5%
C10	1608 CAP	3.9pF	±5%
C11	1608 CAP	10pF	±5%
C12	1608 CAP	8pF	±5%
L1	1608 IND	33nH	±5%
L2	1608 IND	6.8nH	±5%
R1	1608 RES	4.3kohn	±5%
R2	1608 RES	100ohm	±5%
R3	1608 RES	0ohm	±5%
Q1	SOIC-8 PKG	BT331	

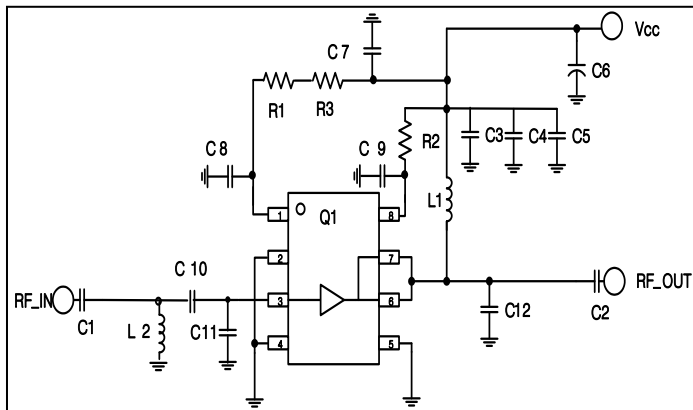

Note:

1. PCB: 31mil thick FR4
2. Distance between the center of the shunt Inductor (L2) and the input pin of BT331 is 5.25 mm.
3. Distance between the center of the shunt cap (C10) and the input pin of BT331 is 3.70 mm.
4. Distance between the center of the shunt cap (C11) and the input pin of BT331 is 1.50 mm.
5. Distance between the center of the shunt cap (C12) and the output pin of BT331 is 8.25 mm

TITLE

BT331 Evaluation Board

(836 MHz)

Drawing Number	Rev.
Date	Drawn By
2011/04/11	YH, Kwon
FILE NAME	SHEET

1.1 BT331_836MHz Test Result

SN	Freq [MHz]	Vcc [V]	Icc [mA]	Gain [dB]	OIP3 [dBm] ⁽¹⁾	P1dB [dBm]	IRL [dB]	ORL [dB]	NF [dB]
-	836	5	426	20.1	48.4	32.4	19.8	8.1	5.1

(1) OIP3 was tested @Pout=20dBm/tone (CW) 1MHz tone space

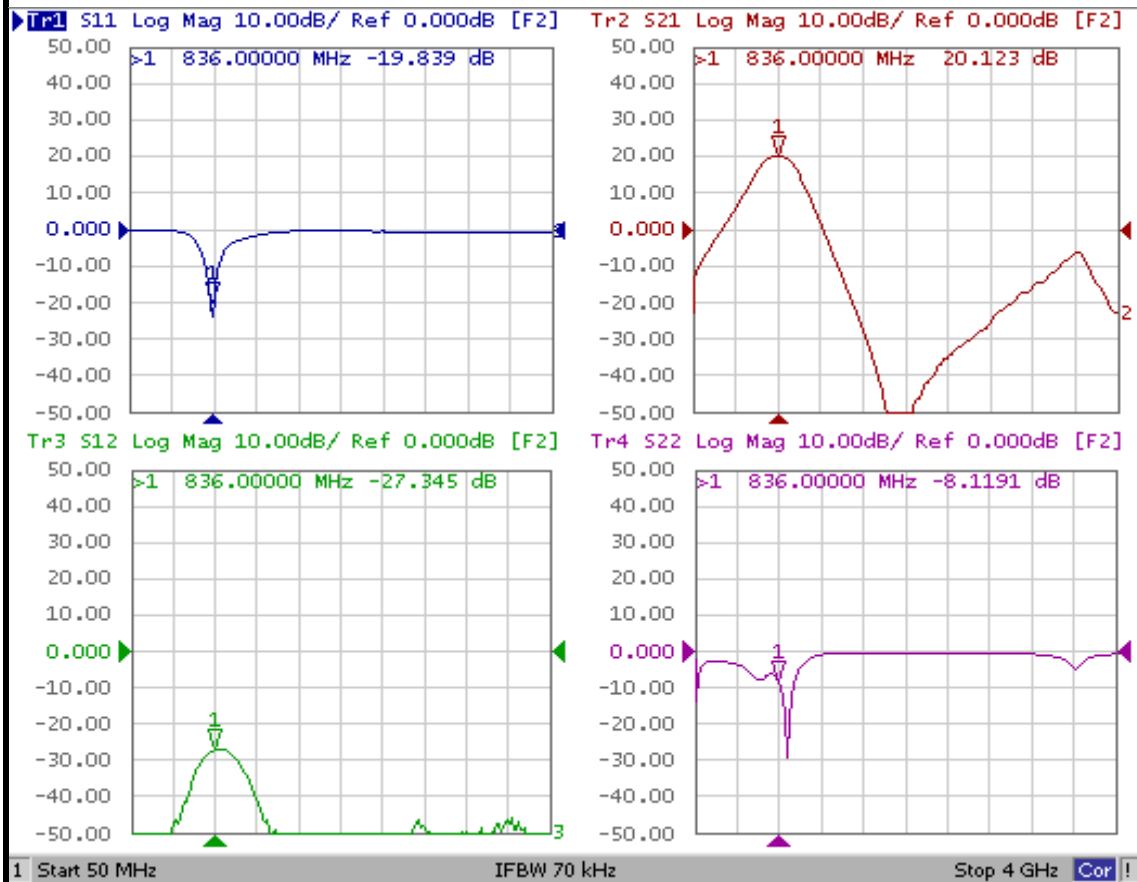

2. BT331_ 836MHz (Resistor Insertion) Application Note

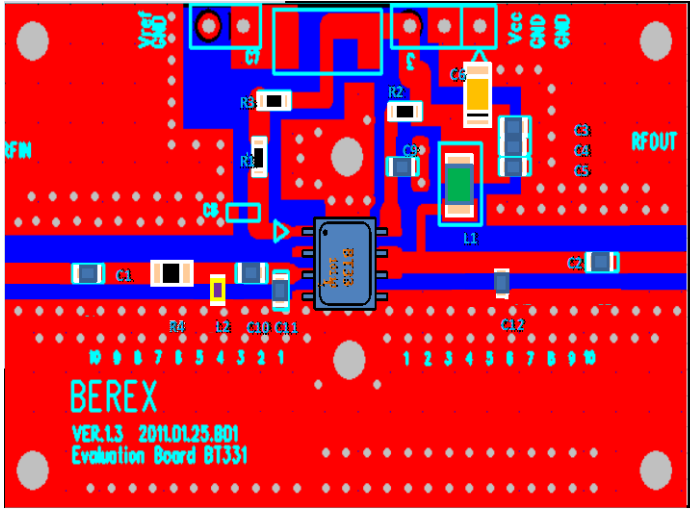

Ref. Des.	Description/ Part Number	Values	Tolerance
C1	1608 CAP	100pF	±5%
C2	1608 CAP	100pF	±5%
C3	1608 CAP	100pF	±5%
C4	1608 CAP	1000pF	±5%
C5	1608 CAP	1uF	±5%
C6	3216 Tantal	10uF	±20%
C7		DNP	
C8		DNP	
C9	1608 CAP	1pF	±5%
C10	1608 CAP	3.9pF	±5%
C11	1608 CAP	10pF	±5%
C12	1608 CAP	8pF	±5%
L1	1608 IND	33nH	±5%
L2	1608 IND	6.8nH	±5%
R1	1608 RES	4.3kohn	±5%
R2	1608 RES	100ohm	±5%
R3	1608 RES	0ohm	±5%
R4	1608 RES	22ohm	±5%
Q1	SOIC-8 PKG	BT331	

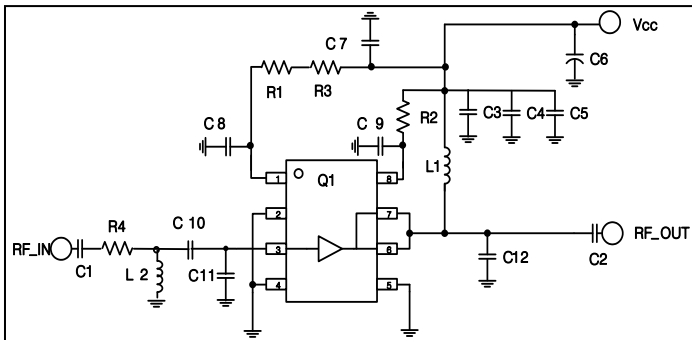

Note:

1. PCB: 31mil thick FR4
2. Distance between the center of thshunt Resistance (R4) and the input pin of BT331 is10.0 mm.
3. Distance between the center of the shunt Inductor (L2) and the input pin of BT331 is 5.25 mm.
4. Distance between the center of the shunt cap (C10) and the input pin of BT331is3.70mm.
- 5..Distance between the center of the shunt cap(C11)and the input pin of BT331 is1.50 mm.
6. Distance between the center of the shunt cap (C12) and the output pin ofBT331is8.25mm

TITLE	
BT331 Evaluation Board	
(836 MHz)	
Drawing Number	Rev.
Date	Drawn By
2011/04/11	YH, Kwon
FILE NAME	SHEET

2.1 BT331_836MHz (Resiser Insertion) Test Result

SN	Freq [MHz]	Vcc [V]	Icc [mA]	Gain [dB]	OIP3 [dBm] ⁽¹⁾	P1dB [dBm]	IRL [dB]	ORL [dB]	NF [dB]
-	836	5	427	18.2	50.8	32.3	18.8	9.2	7.2

(1) OIP3 was tested @Pout=20dBm/tone (CW) 1MHz tone space

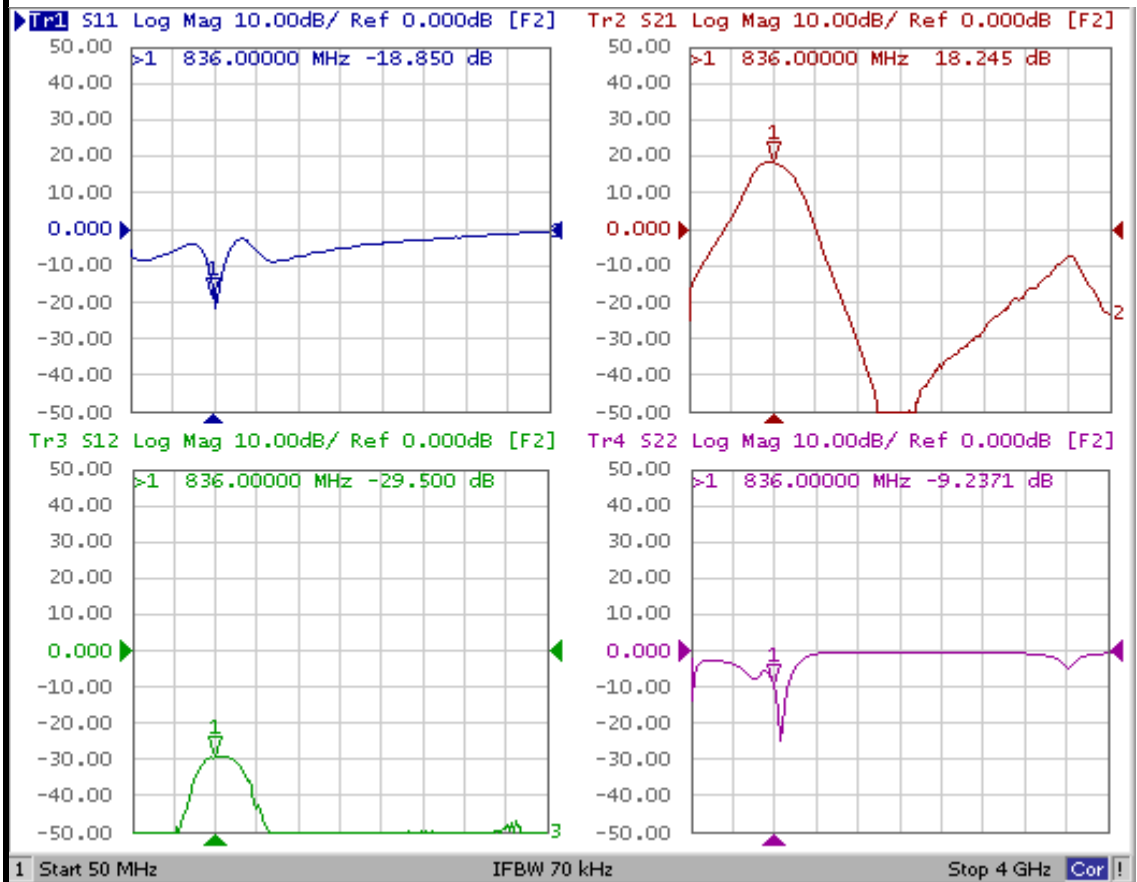

3. BT331_CDMA(824~894MHz) Application Note

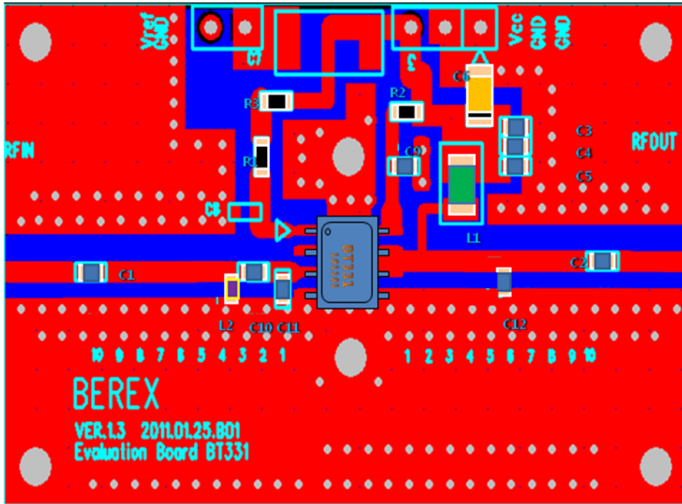

Ref. Des.	Description/ Part Number	Values	Tolerance
C1	1608 CAP	100pF	±5%
C2	1608 CAP	100pF	±5%
C3	1608 CAP	100pF	±5%
C4	1608 CAP	1000pF	±5%
C5	1608 CAP	1uF	±5%
C6	3216 Tantal	10uF	±20%
C7		DNP	
C8		DNP	
C9	1608 CAP	1pF	±5%
C10	1608 CAP	3.9pF	±5%
C11	1608 CAP	10pF	±5%
C12	1608 CAP	8pF	±5%
L1	1608 IND	33nH	±5%
L2	1608 IND	6.8nH	±5%
R1	1608 RES	4.3kohn	±5%
R2	1608 RES	100ohm	±5%
R3	1608 RES	0ohm	±5%
Q1	SOIC-8 PKG	BT331	

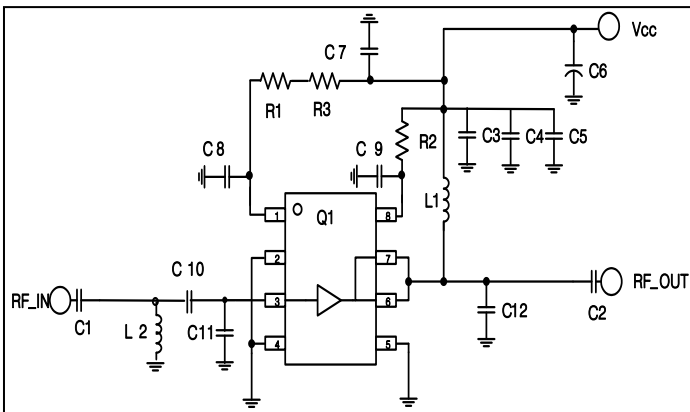

Note:

1. PCB: 31mil thick FR4
2. Distance between the center of the shunt Inductor (L2) and the input pin of BT331 is 5.25 mm.
3. Distance between the center of the shunt cap (C10) and the input pin of BT331 is 3.70 mm.
4. Distance between the center of the shunt cap (C11) and the input pin of BT331 is 1.50 mm.
5. Distance between the center of the shunt cap (C12) and the output pin of BT331 is 8.25 mm.

TITLE	
BT331 Evaluation Board	
(824~894 MHz)	
Drawing Number	Rev.
Date	Drawn By
2011/04/11	YH, Kwon
FILE NAME	SHEET

3.1 BT331_CDMA(824~894MHz) Test Result

SN	Freq [MHz]	Vcc [V]	Icc [mA]	Gain [dB]	OIP3 [dBm] ⁽¹⁾	P1dB [dBm]	IRL [dB]	ORL [dB]	NF [dB]
-	824	5	420	20.1	49.5	32.3	21.0	7.2	5.3
-	848	5	420	20.0	47.8	32.0	19.1	8.6	5.3
-	894	5	420	19.8	48.5	31.3	11.6	14.5	5.3

(1) OIP3 was tested @Pout=20dBm/tone (CW) 1MHz tone space

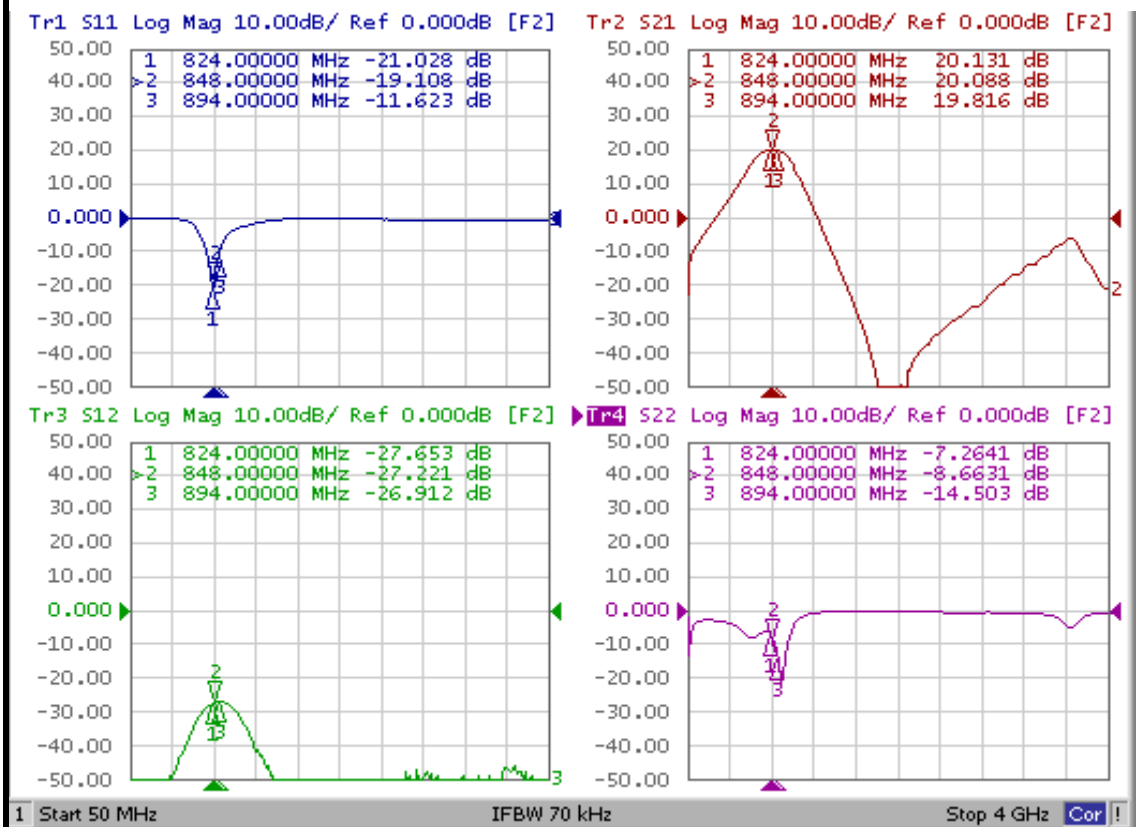

3.2 BT331_CDMA(824~894MHz) ACPR

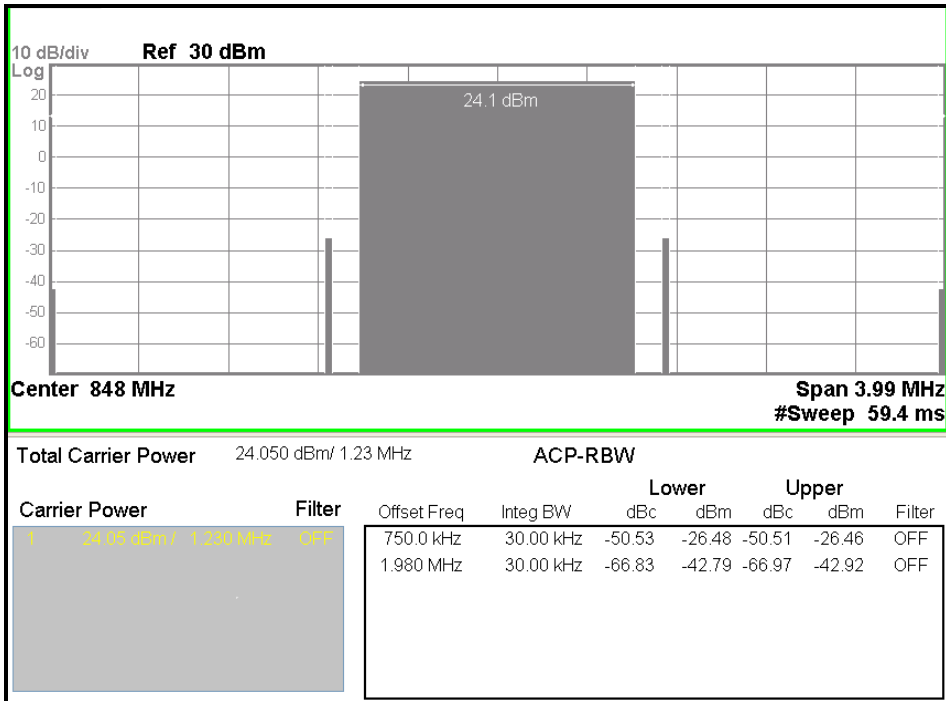

[Test condition]

1FA / 750KHz- 50dBc@ Output power 24.1dBm

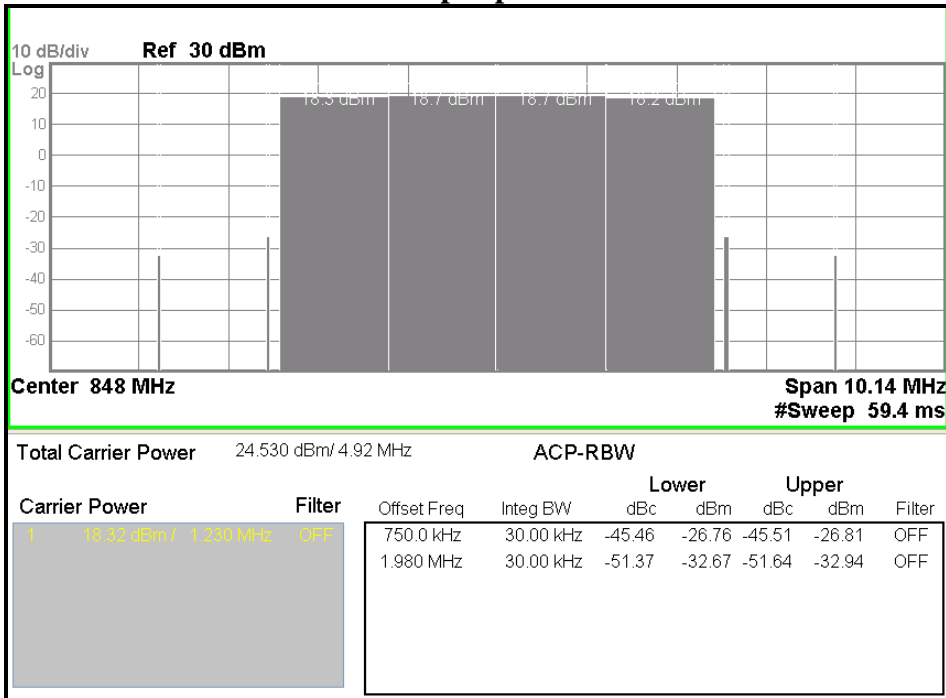

[Test condition]

4FA / 750KHz- 45dBc@ Output power 24.5dBm

4. BT331_900MHz (Resistor Insertion) Application Note

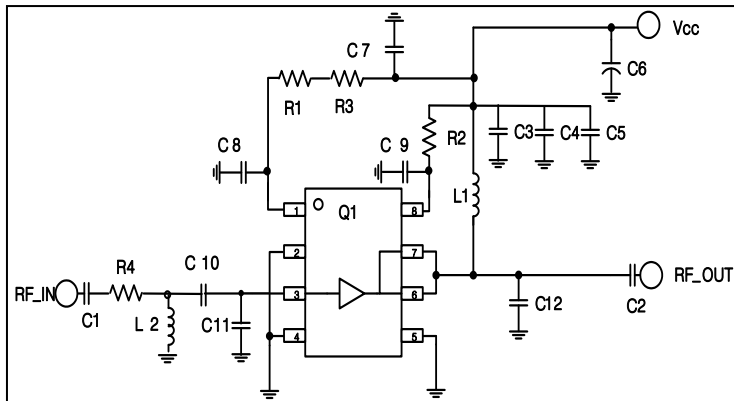
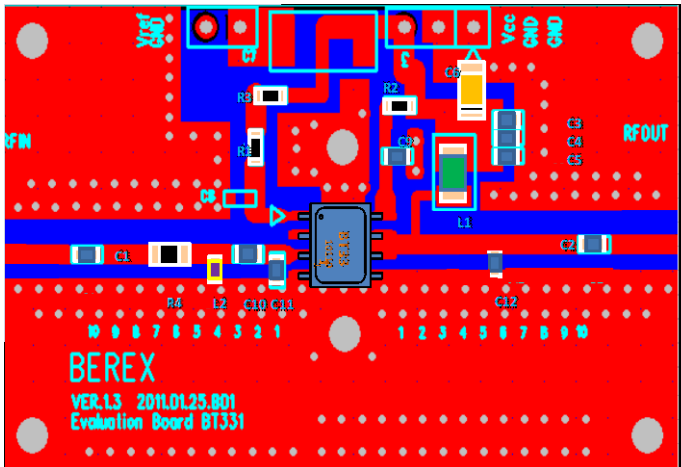

Ref. Des.	Description/ Part Number	Values	Tolerance
C1	1608 CAP	100pF	±5%
C2	1608 CAP	100pF	±5%
C3	1608 CAP	100pF	±5%
C4	1608 CAP	1000pF	±5%
C5	1608 CAP	1uF	±5%
C6	3216 Tantal	10uF	±20%
C7		DNP	
C8		DNP	
C9	1608 CAP	1pF	±5%
C10	1608 CAP	3.3pF	±5%
C11	1608 CAP	10pF	±5%
C12	1608 CAP	8pF	±5%
L1	1608 IND	18nH	±5%
L2	1608 IND	8.2nH	±5%
R1	1608 RES	4.3kohn	±5%
R2	1608 RES	100ohm	±5%
R3	1608 RES	0ohm	±5%
R4	1608 RES	36ohm	±5%
Q1	SOIC-8 PKG	BT331	

Note:

1. PCB: 31mil thick FR4
2. Distance between the center of theshunt Resistance (R4) and the input pin of BT331 is 10.0 mm.
3. Distance between the center of theshunt Inductor (L2) and the input pin of BT331 is 6.45 mm.
4. Distance between the center of the shunt cap (C10) and the input pin of BT331 is 3.70 mm.
5. Distance between the center of the shunt cap (C11) and the input pin of BT331 is 1.50 mm.
6. Distance between the center of the shunt cap (C12) and the output pin of BT331 is 8.25mm

TITLE	
BT331 Evaluation Board	
(900 MHz)	
Drawing Number	Rev.
Date	Drawn By
2011/04/11	YH, Kwon
FILE NAME	SHEET

4.1 BT331_900MHz(Resister Insertion) Test Result

SN	Freq [MHz]	Vcc [V]	Icc [mA]	Gain [dB]	OIP3 [dBm] ⁽¹⁾	P1dB [dBm]	IRL [dB]	ORL [dB]	NF [dB]
-	900	5	420	16.9	48	32.3	11.6	14.4	7.2

(1) OIP3 was tested @Pout=20dBm/tone (CW) 1MHz tone space

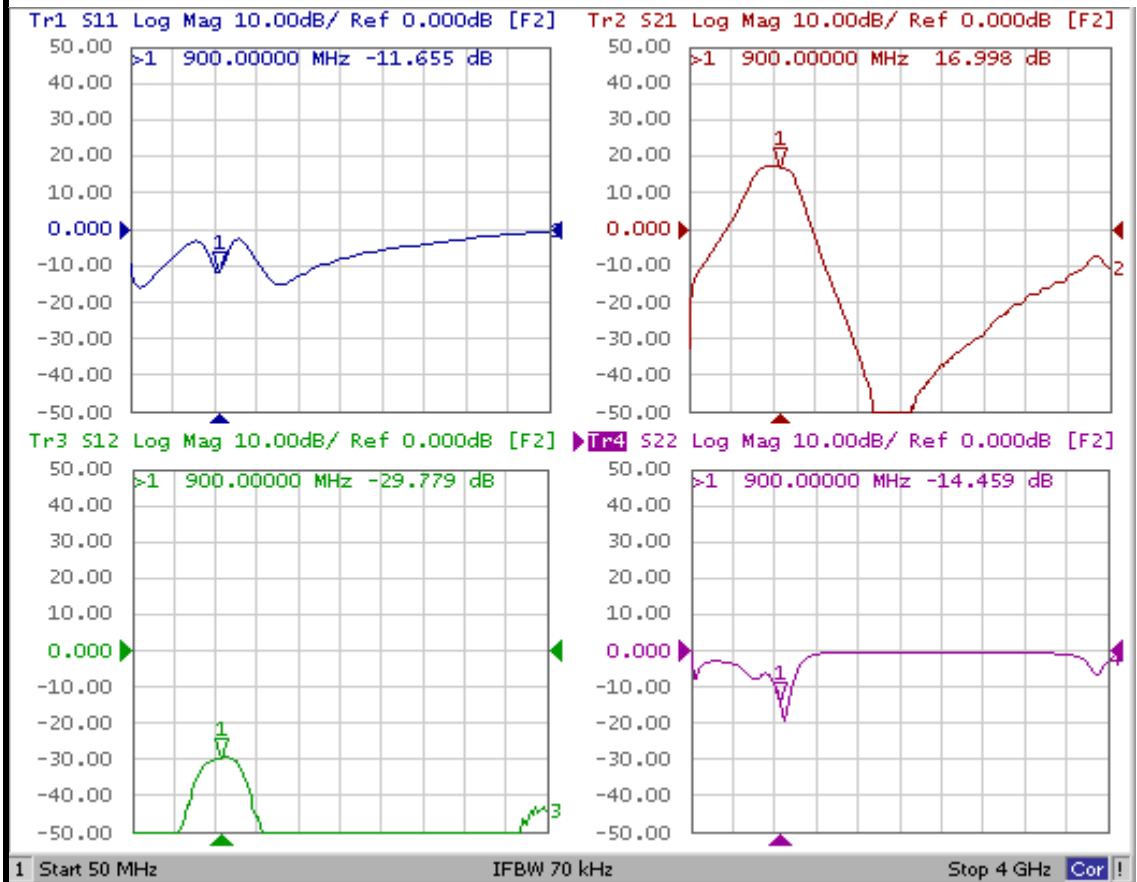

5 BT331_WCMDA(920~960)MHz Application Note

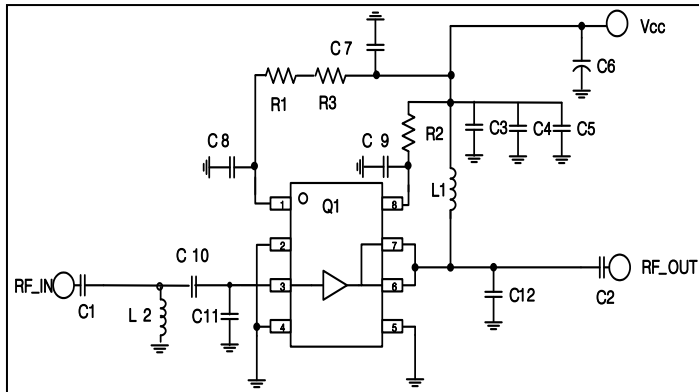
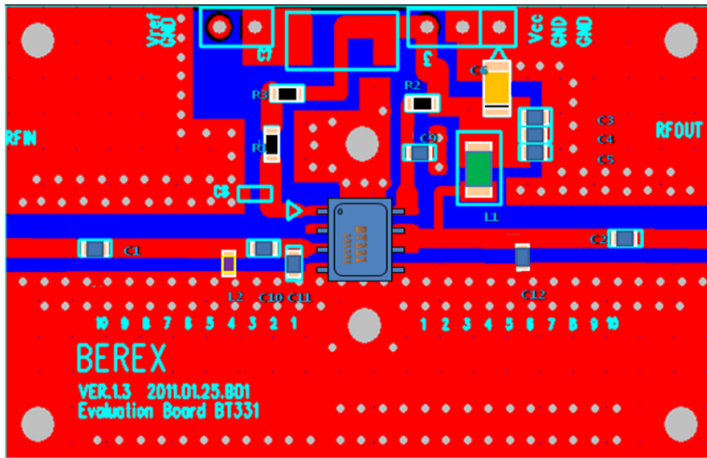

Ref. Des.	Description/ Part Number	Values	Tolerance
C1	1608 CAP	100pF	±5%
C2	1608 CAP	100pF	±5%
C3	1608 CAP	100pF	±5%
C4	1608 CAP	1000pF	±5%
C5	1608 CAP	1uF	±5%
C6	3216 Tantal	10uF	±5%
C7		DNP	
C8		DNP	
C9	1608 CAP	1pF	±5%
C10	1608 CAP	3.3pF	±5%
C11	1608 CAP	10pF	±5%
C12	1608 CAP	7pF	±5%
L1	1608 IND	33nH	±5%
L2	1608 IND	8.2nH	±5%
R1	1608 RES	4.3kohn	±5%
R2	1608 RES	100ohm	±5%
R3	1608 RES	0ohm	±5%
Q1	SOIC-8 PKG	BT331	

Note:

1. PCB: 31mil thick FR4
2. Distance between the center of the shunt Inductor (L2) and the input pin of BT331 is 6.45 mm.
3. Distance between the center of the shunt cap (C10) and the input pin of BT331 is 3.70 mm.
4. Distance between the center of the shunt cap (C11) and the input pin of BT331 is 1.50 mm.
5. Distance between the center of the shunt cap (C12) and the output pin of BT331 is 8.25 mm

TITLE	
BT331 Evaluation Board	
(920~960 MHz)	
Drawing Number	Rev.
Date	Drawn By
2011/04/11	YH, Kwon
FILE NAME	SHEET

5.1 BT331_WCDMA(920~960MHz) Test Result

SN	Freq [MHz]	Vcc [V]	Icc [mA]	Gain [dB]	OIP3 [dBm] ⁽¹⁾	P1dB [dBm]	IRL [dB]	ORL [dB]	NF [dB]
-	920	5	410	19.1	49.0	32.4	22.8	7.9	5.2
-	940	5	410	19.0	47.9	32.3	17.7	9.2	5.2
-	960	5	410	18.9	48.0	31.9	14.2	11.3	5.2

(1) OIP3 was tested @Pout=20dBm/tone (CW) 1MHz tone spacc

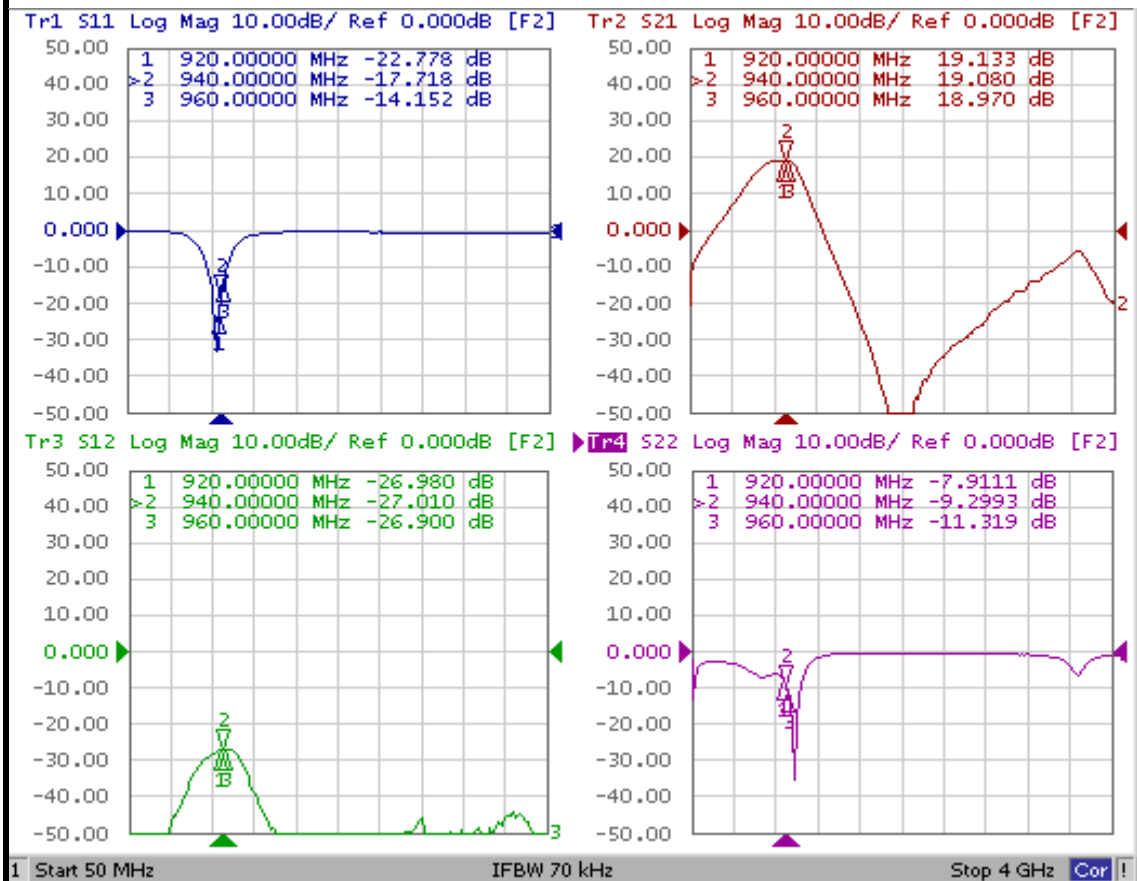

5.2 BT331_WCDMA(920~960MHz) ACLR

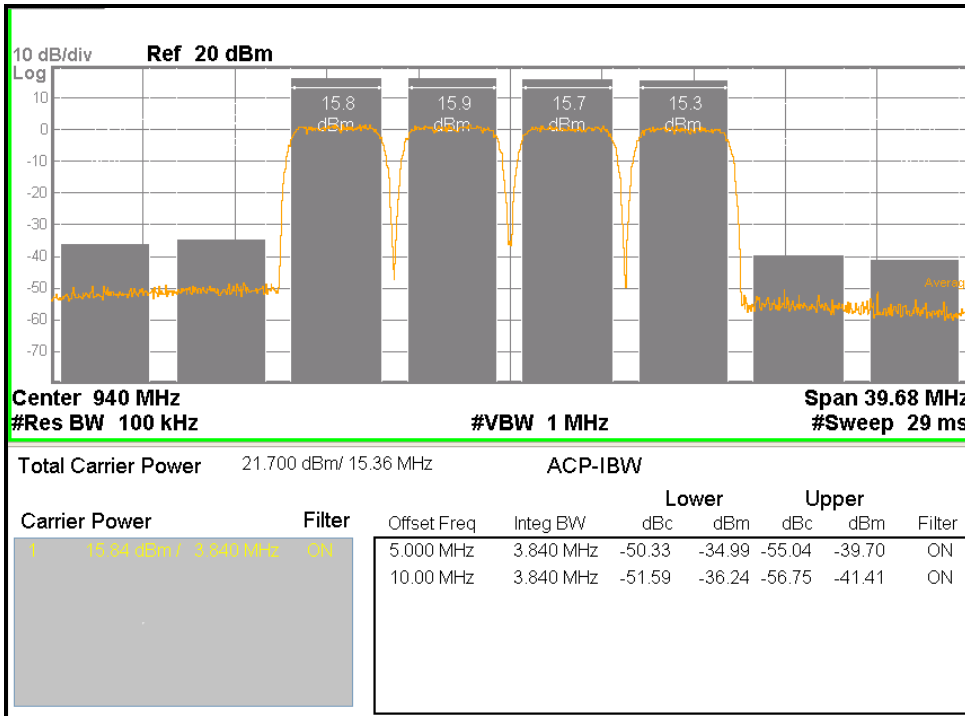

[Test condition]

⇒ 4FA / 5MHz- 50dBc@Output power 21.7dBm

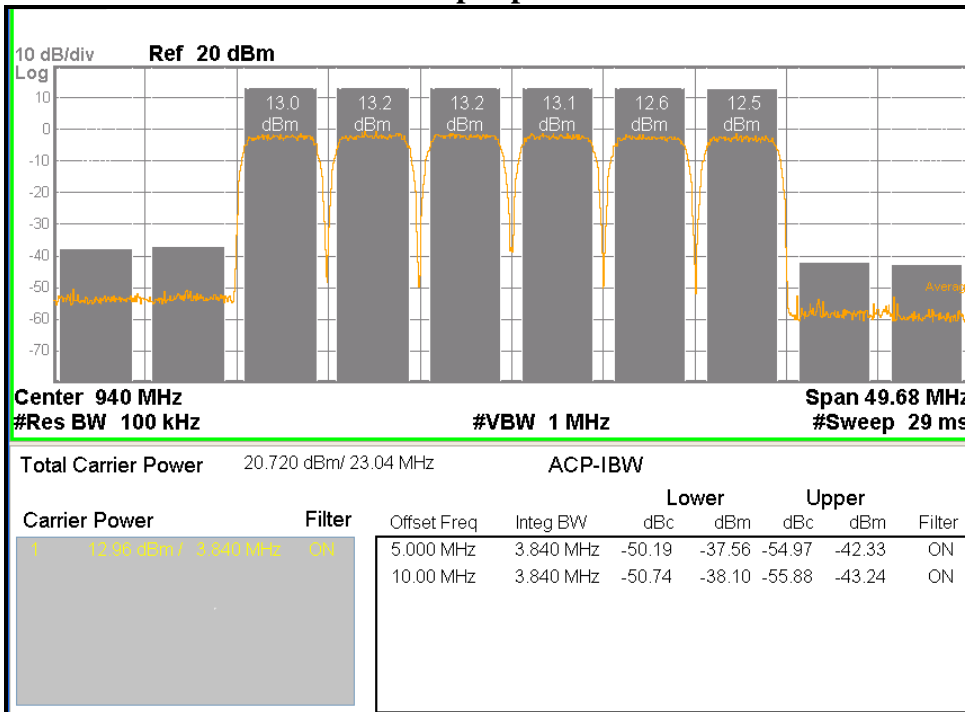

[Test condition]

⇒ 6FA / 5MHz- 50dBc@Output power 20.7dBm

6. BT331_PCS(1840~1870MHz) Application Note

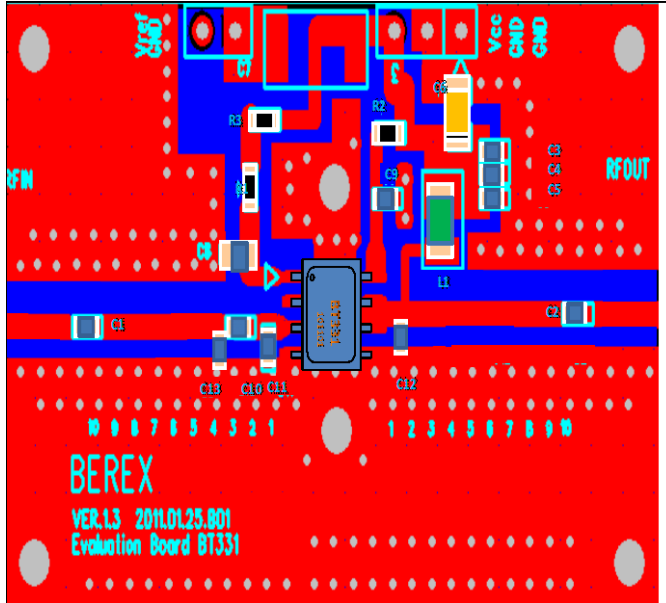

Ref. Des.	Description/ Part Number	Values	Tolerance
C1	1608 CAP	100pF	±5%
C2	1608 CAP	100pF	±5%
C3	1608 CAP	100pF	±5%
C4	1608 CAP	1000pF	±5%
C5	1608 CAP	1uF	±5%
C6	3216 Tantal	10uF	±5%
C7		DNP	
C8	1608 CAP	2pF	±5%
C9	1608 CAP	1.8pF	±5%
C10	1608 CAP	3pF	±5%
C11	1608 CAP	0.5pF	±5%
C12	1608 CAP	2.7pF	±5%
C13	1608 CAP	3pF	±5%
L1	1608 IND	56nH	±5%
R1	1608 RES	4.3kohn	±5%
R2	1608 RES	100ohm	±5%
R3	1608 RES	0ohm	±5%
Q1	SOIC-8 PKG	BT331	

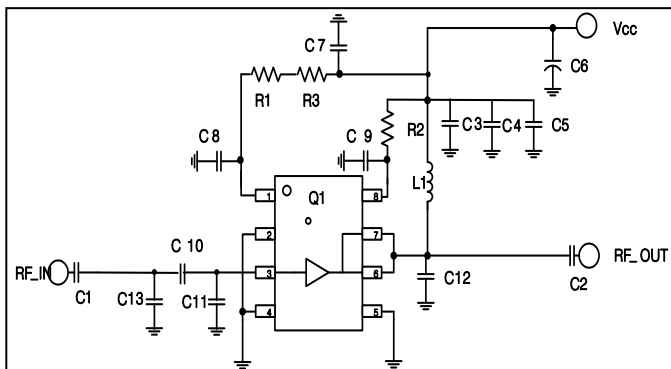

Note:

1. PCB: 31mil thick FR4
2. Distance between the center of the shunt Inductor(C13 and the input pin of BT331 is 5.25mm.
3. Distance between the center of the shunt cap (C10) and the input pin of BT331 is 3.70 mm.
- 4.Distance between the center of the shunt cap (C11) and the input pin of BT331 is 1.50 mm.
5. Distance between the center of the shunt cap (C12) and the output pin of BT331 is 2.25 mm

TITLE	
BT331 Evaluation Board	
(1840~1870 MHz)	
Drawing Number	Rev.
Date	Drawn By
2011/04/11	YH, Kwon
FILE NAME	SHEET

6.1 BT331_PCS(1840~1870MHz)Test Result

SN	Freq [MHz]	Vcc [V]	Icc [mA]	Gain [dB]	OIP3 [dBm] ⁽¹⁾	P1dB [dBm]	IRL [dB]	ORL [dB]	NF [dB]
-	1840	5	408	14.5	50.8	33.4	17.8	11.5	5.1
-	1855	5	408	14.4	49.7	33.5	16.1	12.3	5.1
-	1870	5	408	14.3	48.8	33.6	13.7	13.4	5.14

(1) OIP3 was tested @Pout=20dBm/tone (CW) 1MHz tone space

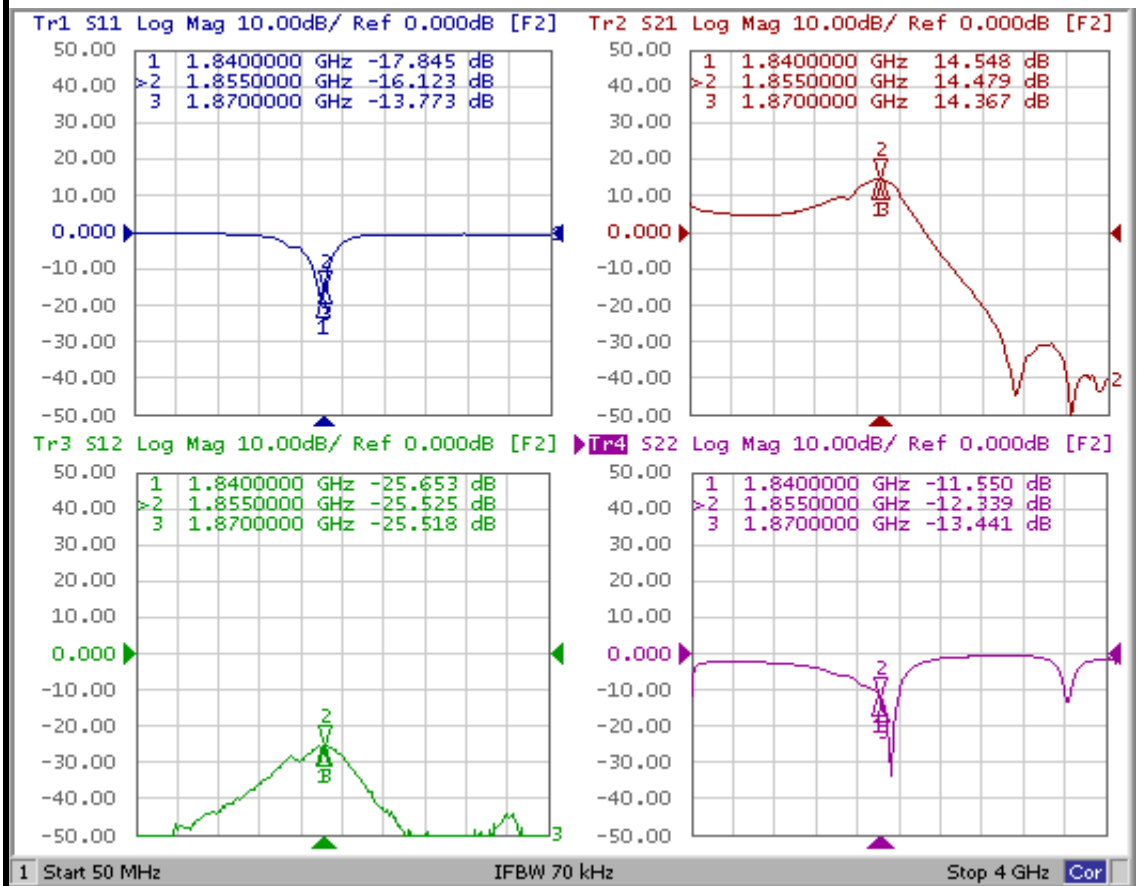

6.2 BT331_PCS(1840~1870MHz) ACPR

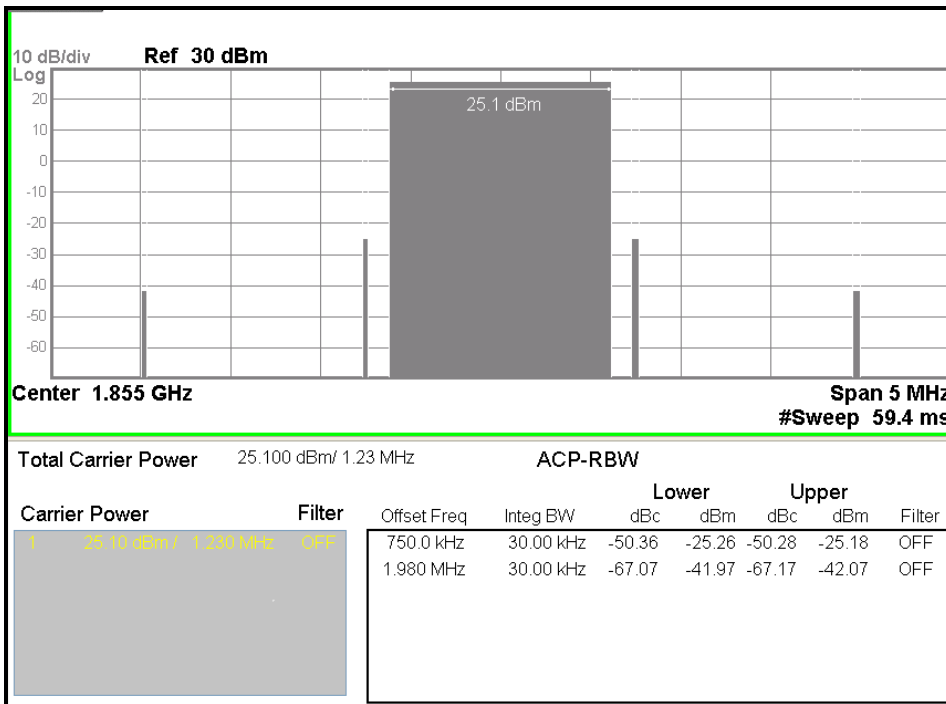

[Test condition]

⇒ 1FA / 750KHz- 50dBc@Output power 25.1dBm

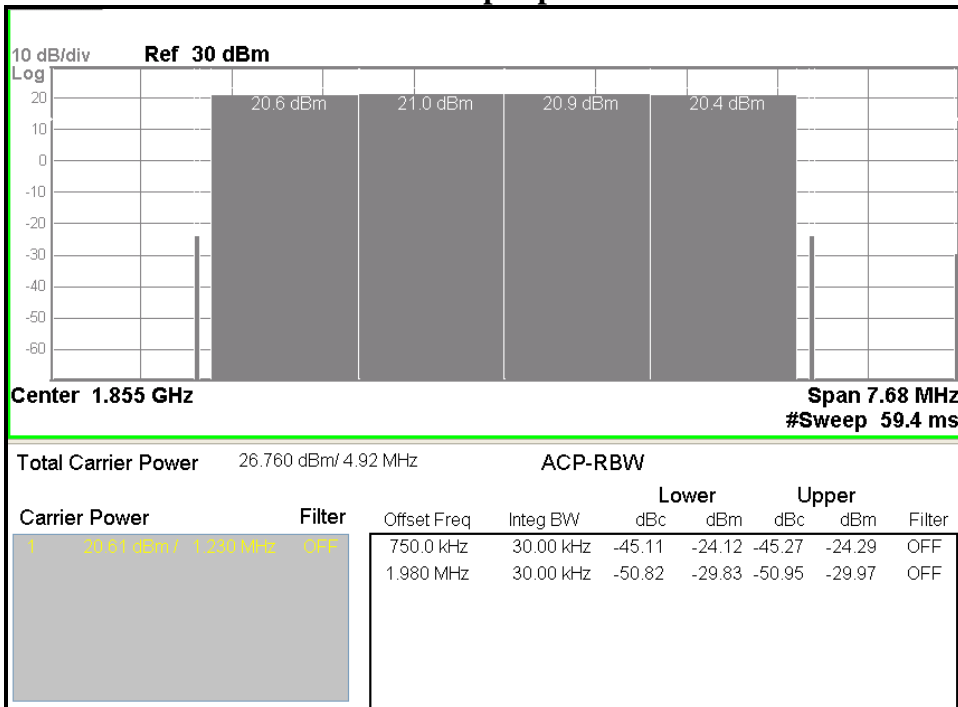

[Test condition]

4FA / 750KHz- 45dBc@Output power 26.8dBm

7. BT331_WCDMA(2110~2170MHz) Application Note

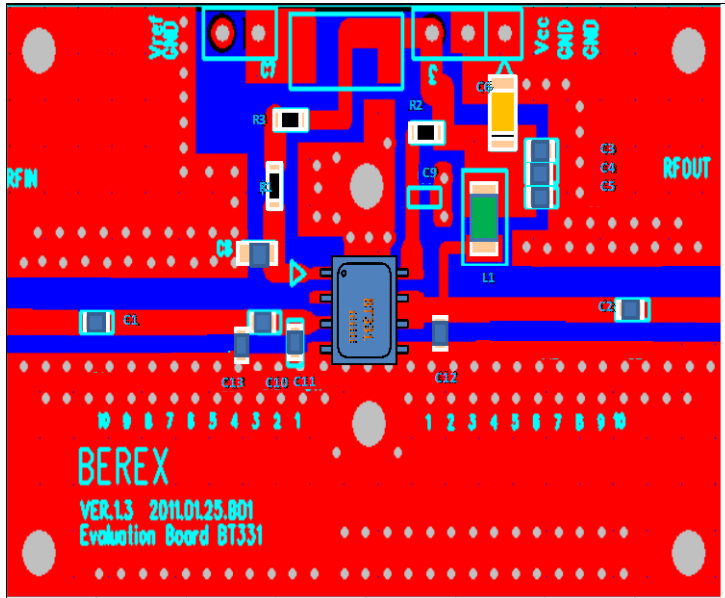

Ref. Des.	Description/ Part Number	Values	Tolerance
C1	1608 CAP	100pF	±5%
C2	1608 CAP	100pF	±5%
C3	1608 CAP	100pF	±5%
C4	1608 CAP	1000pF	±5%
C5	1608 CAP	1uF	±5%
C6	3216 Tantal	10uF	±5%
C7		DNP	
C8	1608 CAP	5pF	±5%
C9		DNP	
C10	1608 CAP	1.8pF	±5%
C11	1608 CAP	0.5pF	±5%
C12	1608 CAP	2pF	±5%
C13	1608 CAP	2pF	±5%
L1	1608 IND	22nH	±5%
R1	1608 RES	5.6kohn	±5%
R2	1608 RES	100ohm	±5%
R3	1608 RES	0ohm	±5%
Q1	SOIC-8 PKG	BT331	

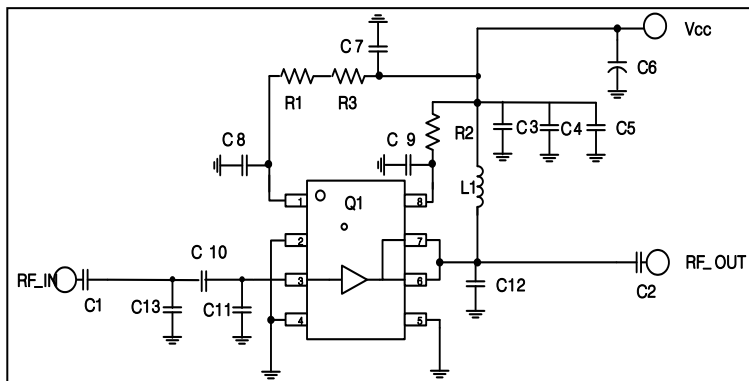

Note:

1. PCB: 31mil thick FR4
2. Distance between the center of the shunt Inductor (C13) and the input pin of BT331 is 5.25 mm.
3. Distance between the center of the shunt cap (C10) and the input pin of BT331 is 3.70 mm.
4. Distance between the center of the shunt cap (C11) and the input pin of BT331 is 1.50 mm.
5. Distance between the center of the shunt cap (C12) and the output pin of BT331 is 2.25 mm.

TITLE	
BT331 Evaluation Board	
(2110~2170 MHz)	
Drawing Number	Rev.
Date	Drawn By
2011/04/11	YH, Kwon
FILE NAME	SHEET

7.1 BT331_WCDMA(2130~2170MHz) Test Result

SN	Freq [MHz]	Vcc [V]	Icc [mA]	Gain [dB]	OIP3 [dBm] ⁽¹⁾	P1dB [dBm]	IRL [dB]	ORL [dB]	NF [dB]
-	2110	5	405	13.2	50.5	32.5	12.5	11.8	5.2
-	2140	5	405	13.4	50	32.4	17.0	13	5.2
-	2170	5	405	13.4	48	32	28.3	15.1	5.2

(1) OIP3 was tested @Pout=20dBm/tone (CW) 1MHz tone space

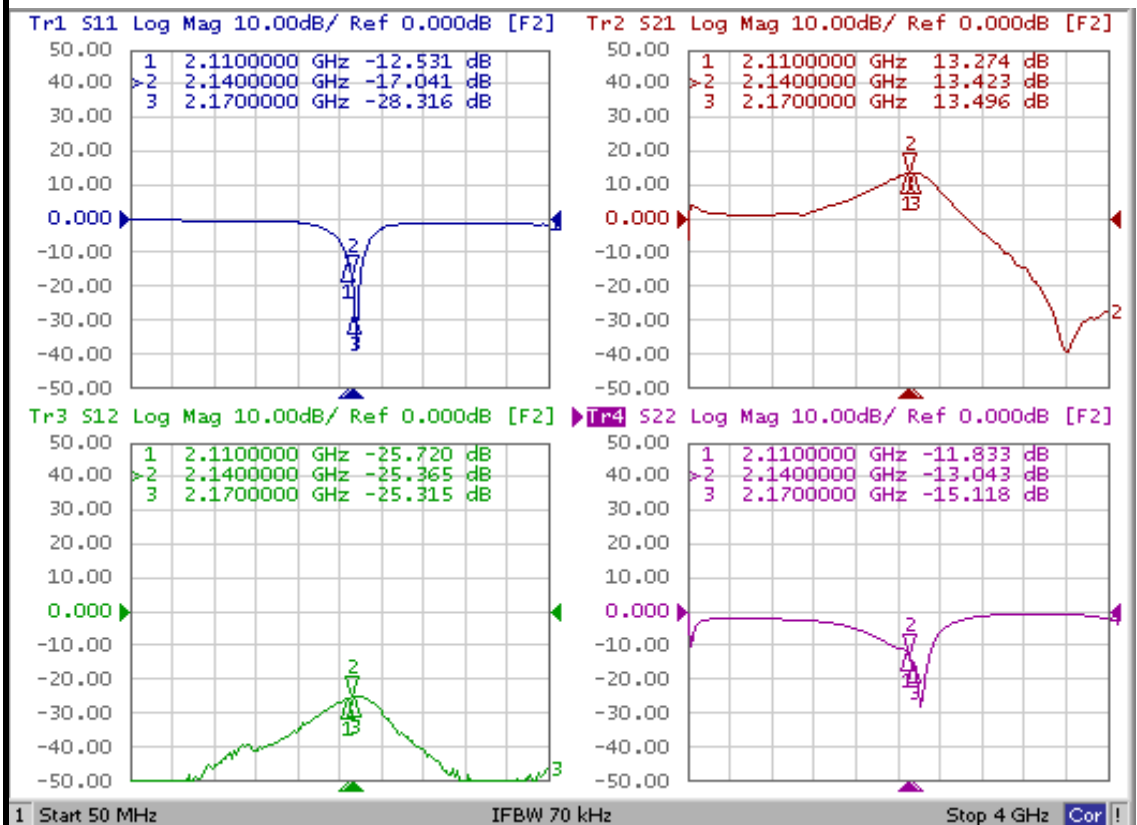

7.2 BT331_WCDMA(2110~2170MHz) ACLR

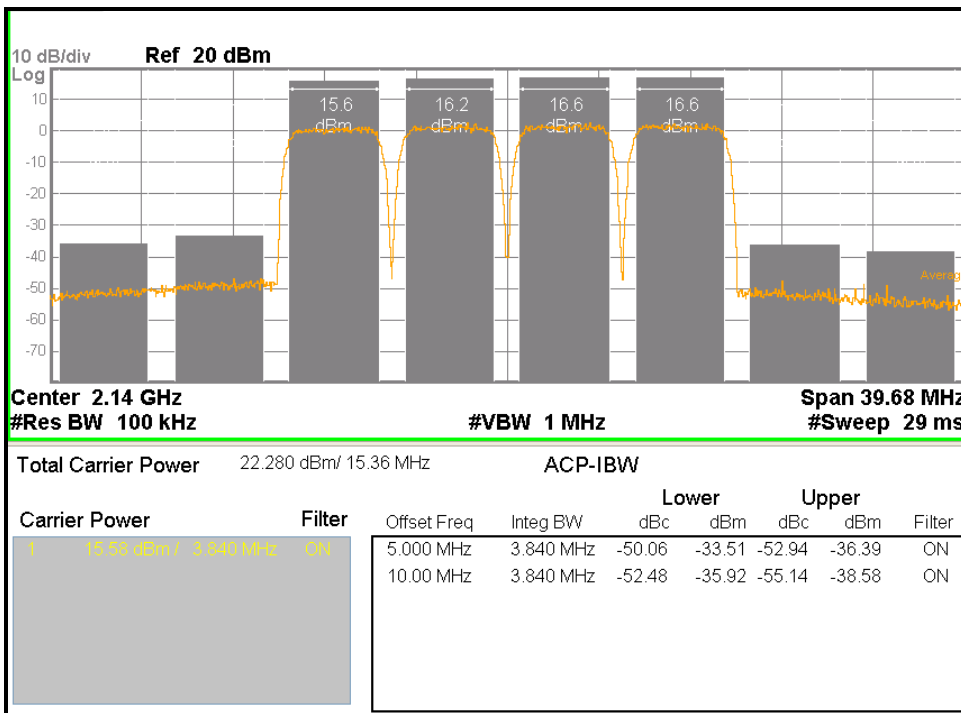

[Test condition]

⇒ 4FA / 5MHz- 50dBc@ Output power 22.3dBm

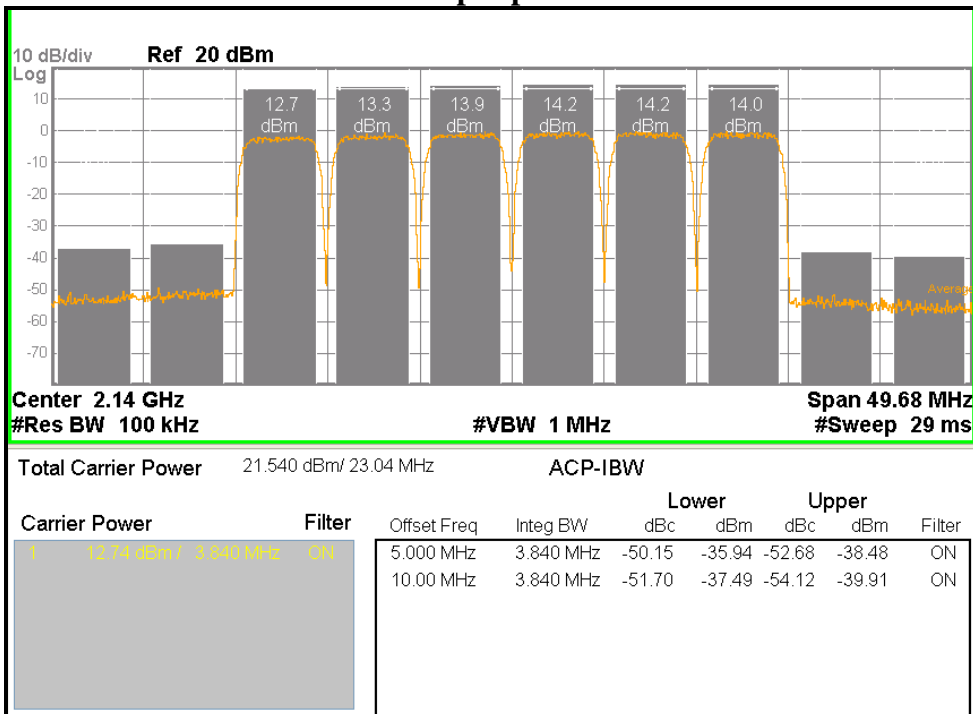

[Test condition]

⇒ 6FA / 5MHz- 50dBc@ Output power 21.5dBm