

### Device Features

- OIP3 = 30 dBm @ 1900 MHz
- Gain = 16.4 dB @ 1900 MHz
- Output P1 dB = 17 dBm @ 1900 MHz
- 50 Ω Cascadable
- Patented temperature compensation
- RoHS2-compliant SOT-89 SMT package



### Product Description

BeRex's BG17C is a high performance InGaP/GaAs HBT MMIC amplifier, internally matched to 50 Ohms and uses a patented **temperature compensation** circuit to provide stable current over the operating temperature range without the need for external components. The BG17C is designed for high linearity gain block applications that require high gain and low power consumption at 5V. It is packaged in a RoHS2-compliant with SOT-89 surface mount package.

### Applications

- Base station Infrastructure/RFID
- Commercial/Industrial/Military wireless system

### Applications Circuit

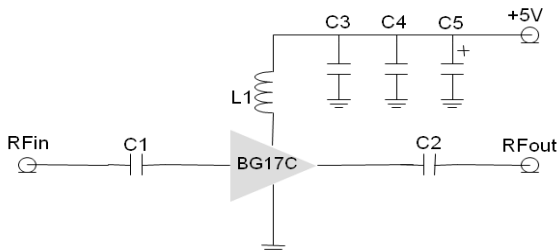

\*C1, C2, C3 = 100 pF ± 5%; C4 = 1000 pF ± 5%; C5 = 10uF; L1 = 33nH

\*less than 20nH improves RF performance at over 1.9GHz.

\*40nH or higher value L1 improves RF performance at under 500MHz.

\*Optimum value of L1 may vary with board design.

### Typical Performance<sup>1</sup>

Parameter	Frequency						Unit
	500	900	1900	2140	3500	5800	
Gain	18.0	17.8	16.4	16.0	14.9	11.0	dB
S11	-15.0	-14.0	-24.0	-16.0	-20.0	-11.4	dB
S22	-14.0	-22.0	-12.0	-11.0	-12.1	-8.0	dB
OIP3 <sup>2</sup>	31.0	31.0	30.0	30.0	27.5	24.5	dBm
P1dB	17.1	17.5	17.0	17.0	15.0	12.3	dBm
N. F	3.8	3.9	4.0	4.0	4.2	6.6	dB

<sup>1</sup> Device performance \_ measured on a BeRex evaluation board at 25°C, 50 Ω system.

<sup>2</sup> OIP3 \_ measured with two tones at an output of 2 dBm per tone separated by 1 MHz.

### Recommended Operating Conditions

Parameter	Min.	Typical	Max.	Unit
Bandwidth	5		6000	MHz
I <sub>c</sub> @ (V <sub>c</sub> = 5V)	45	55	65	mA
V <sub>c</sub>	4.5	5.0	5.5	V
dG/dT		-0.004		dB/°C
R <sub>TH</sub>		50		°C/W

### Absolute Maximum Ratings

Parameter	Rating	Unit
Operating Case Temperature	-40 to +85	°C
Storage Temperature	-55 to +155	°C
Junction Temperature	+170	°C
Supply Voltage	+6.0	V
Supply Current	150	mA
Input RF Power	23	dBm

Operation of this device above any of these parameters may result in permanent damage.

### V-I Characteristics

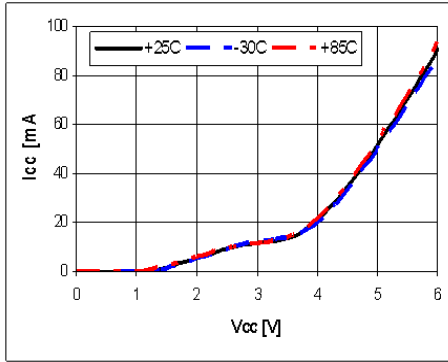

### BeRex SOT89 Evaluation Board

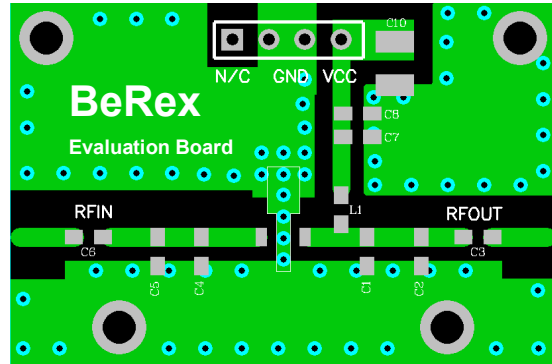

\*Dielectric constant \_ 4.2 \*RF pattern width 52mil \*31mil thick FR4 PCB

### Typical Device Data

S-parameters (Vc=5V, Ic=55mA, T=25°C)

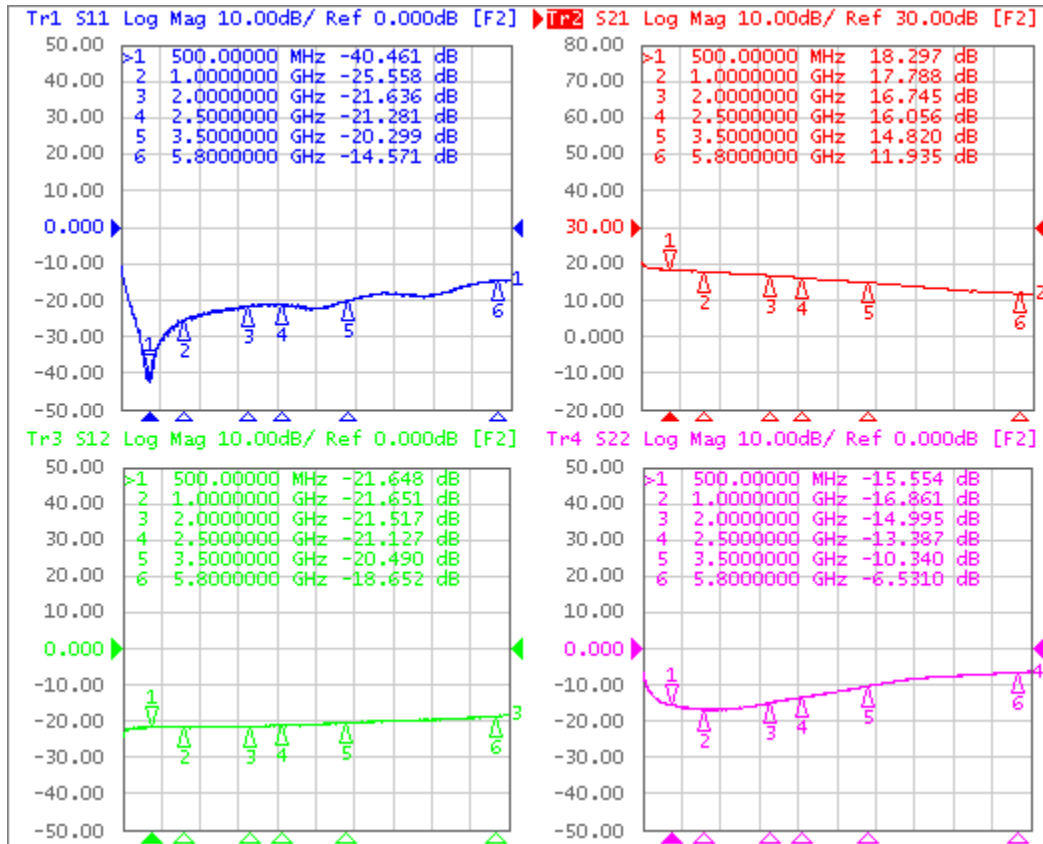

### S-Parameter

(V<sub>device</sub> = 5.0V, I<sub>cc</sub> = 55mA, T = 25 °C, calibrated to device leads)

Freq [MHz]	S11 [Mag]	S11 [Ang]	S21 [Mag]	S21 [Ang]	S12 [Mag]	S12 [Ang]	S22 [Mag]	S22 [Ang]
100	0.18	-61.72	9.39	165.12	0.07	14.00	0.33	-39.57
500	0.01	10.57	8.24	154.56	0.08	1.06	0.17	-40.39
1000	0.05	51.39	7.76	134.93	0.08	-1.88	0.14	-62.54
1500	0.07	24.78	7.29	115.38	0.08	-4.63	0.15	-89.81
2000	0.08	0.55	6.87	96.16	0.08	-7.41	0.18	-112.95
2500	0.09	-8.04	6.35	77.48	0.09	-9.20	0.22	-134.94
3000	0.08	14.14	5.88	60.67	0.09	-12.34	0.25	-157.37
3500	0.10	50.14	5.51	43.30	0.09	-15.00	0.31	179.17
4000	0.12	73.79	5.05	27.13	0.10	-19.42	0.36	161.72
6000	0.18	155.53	3.82	-32.99	0.12	-43.40	0.48	152.34

Typical Performance (V<sub>d</sub> = 5V, I<sub>c</sub> = 55mA, T = 25°C)

Freq	MHz	500	900	1900	2140	2450	3000	3500	5800
S21	dB	18.0	17.8	16.4	16.0	15.6	15.0	14.9	11.0
S11	dB	-15.0	-14.0	-24.0	-16.0	-14.0	-11.0	-20	-11.4
S22	dB	-14.0	-22.0	-12.0	-11.0	-10.0	-9.0	-12.1	-8.0
P1	dBm	17.1	17.5	17.0	17.0	16.1	15.2	15	12.3
OIP3	dBm	31.0	31.0	30.0	30.0	29.0	28.0	27.5	24.5
NF	dB	3.8	3.9	4.0	4.0	4.0	4.2	4.2	6.6

Typical Performance (V<sub>d</sub> = 4.7V, I<sub>c</sub> = 43mA, T = 25°C)

Freq	MHz	70	500	900	1900	2140	2450	3500
S21	dB	20.0	18.0	17.6	16.0	15.8	15.5	14.7
S11	dB	-13	-20.2	-24	-15.3	-14.6	-16.7	-18.9
S22	dB	-5.9	-10.9	-14.7	-10.4	-10.1	-11.2	-11.9
P1	dBm	13.9	14.4	14.9	14.2	13.9	14.6	14.0
OIP3	dBm	28.5	26	27.5	27.5	26.5	27	26
NF	dB	3.8	3.8	3.9	4.0	4.0	4.0	4.2

Typical Performance (V<sub>d</sub> = 4.5V, I<sub>c</sub> = 37mA, T = 25°C)

Freq	MHz	70	500	900	1900	2140	2450	3500
S21	dB	19.5	17.8	17.4	15.9	15.7	15.3	14.6
S11	dB	-12.5	-18.7	-21.7	-14.7	-14.1	-16.1	-18
S22	dB	-5.8	-10.5	-13.9	-10.1	-9.7	-10.9	-11.6
P1	dBm	13.6	14.3	14.3	13.7	13.2	12.7	12.5
OIP3	dBm	27.5	27.0	24.5	24.5	24	24.0	23.5
NF	dB	3.8	3.8	3.9	4.0	4.0	4.0	4.2

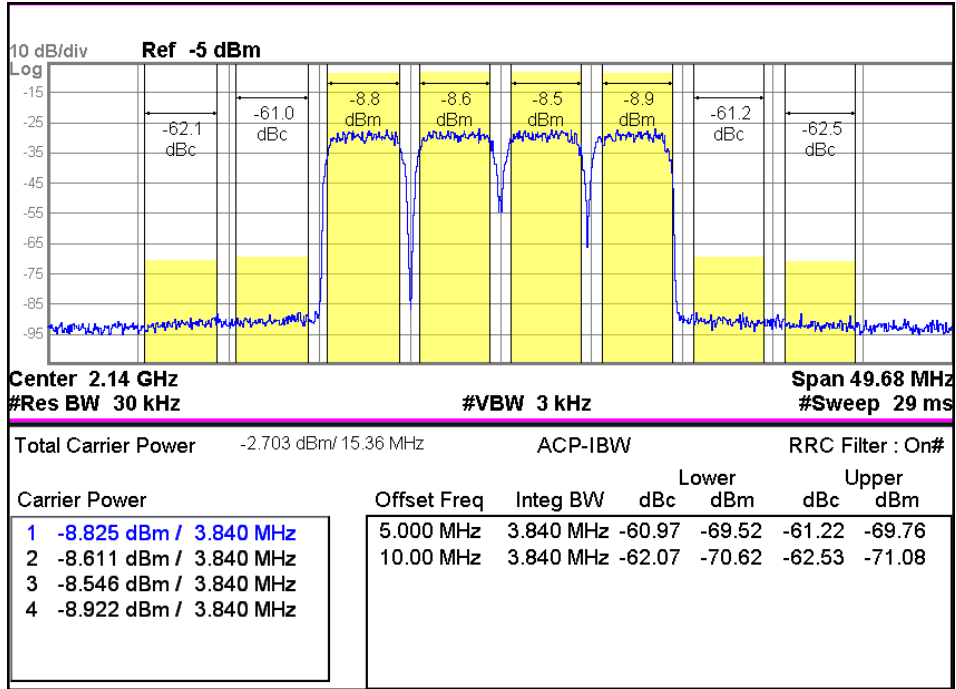
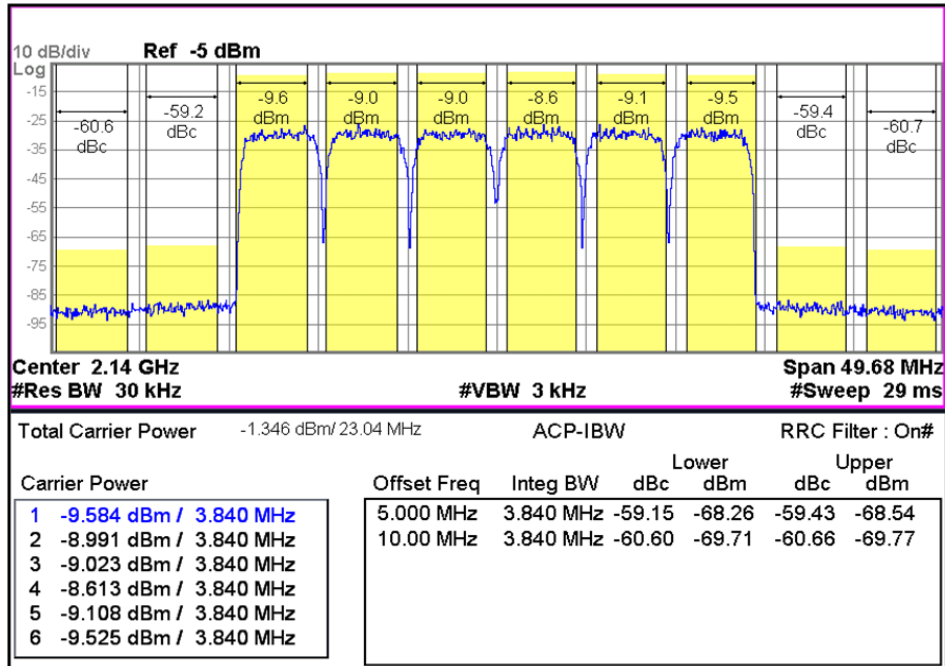
**WCDMA 4FA 2140 -60dBc**

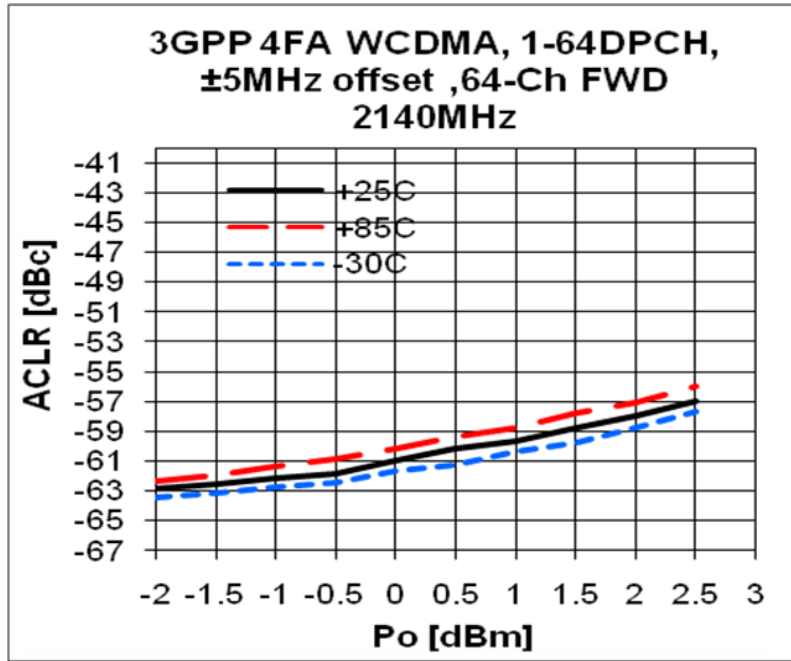
**WCDMA 6FA 2140 -60dBc**

**ACLR**

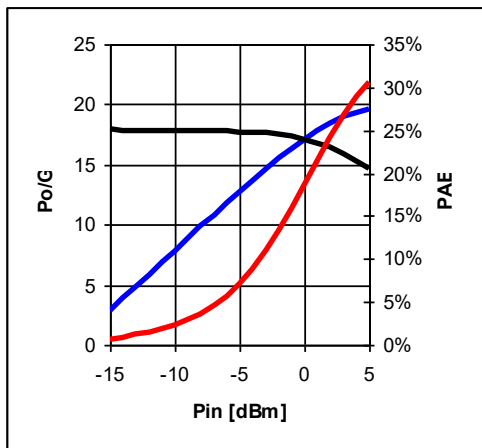
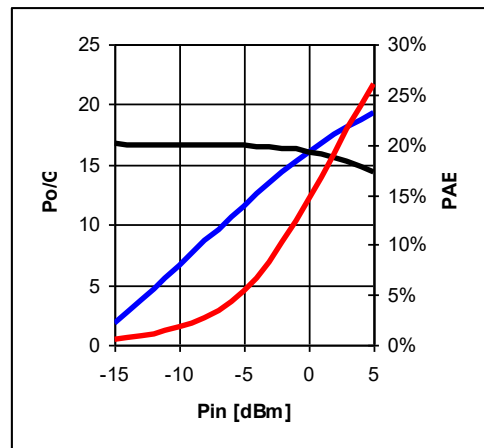
**Device Performance**

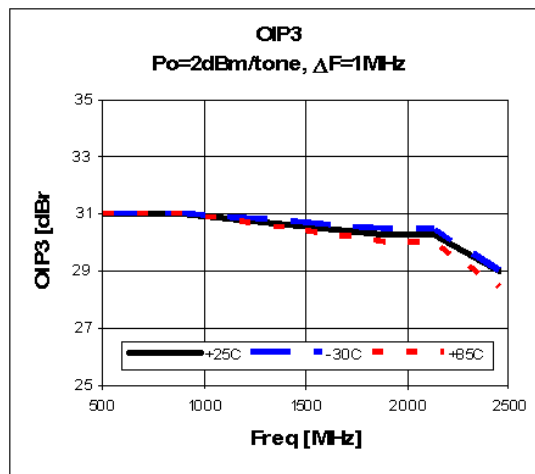
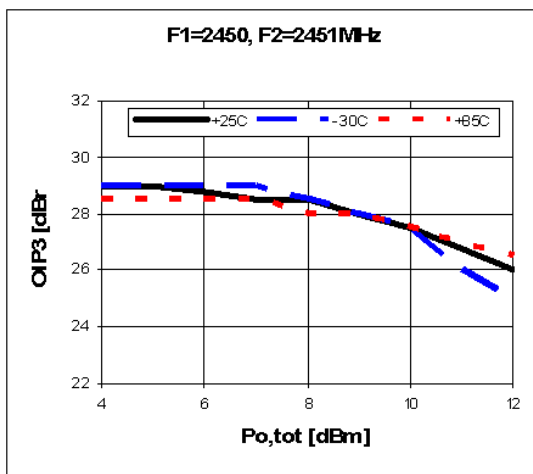
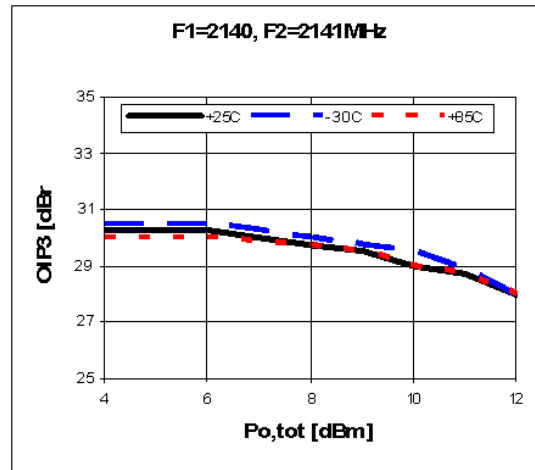
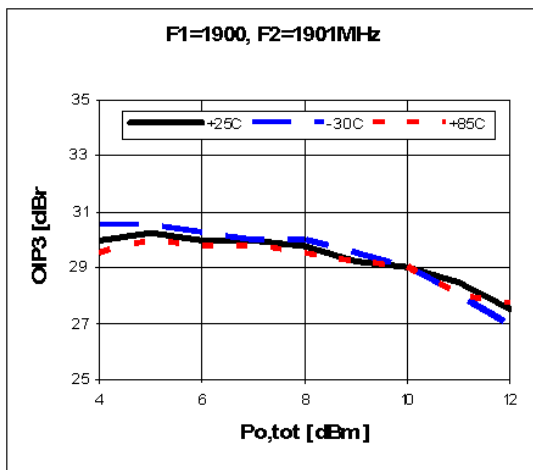
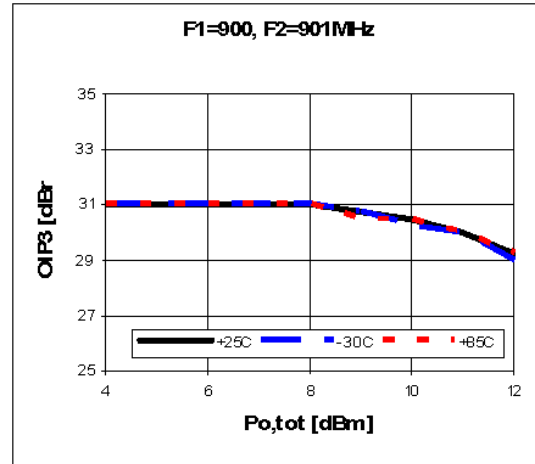
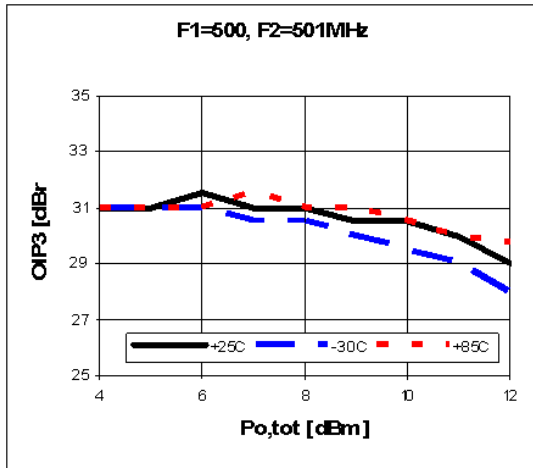
## Pin-Pout-Gain

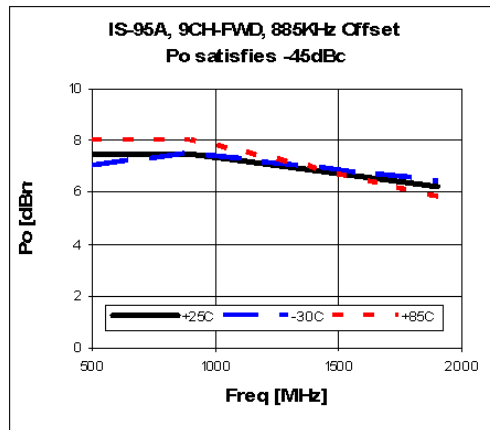
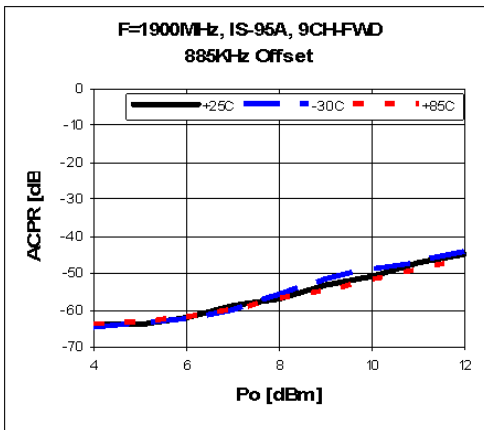
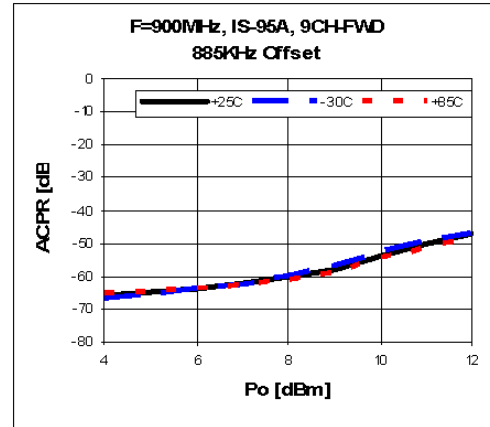
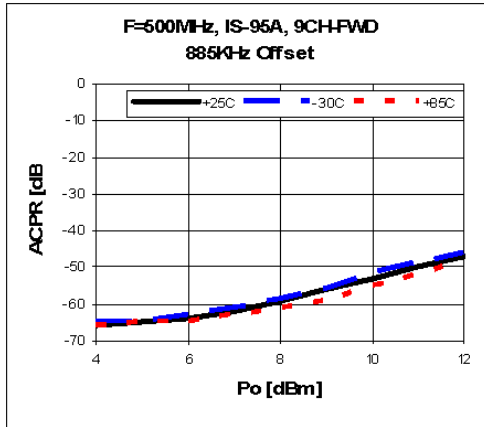
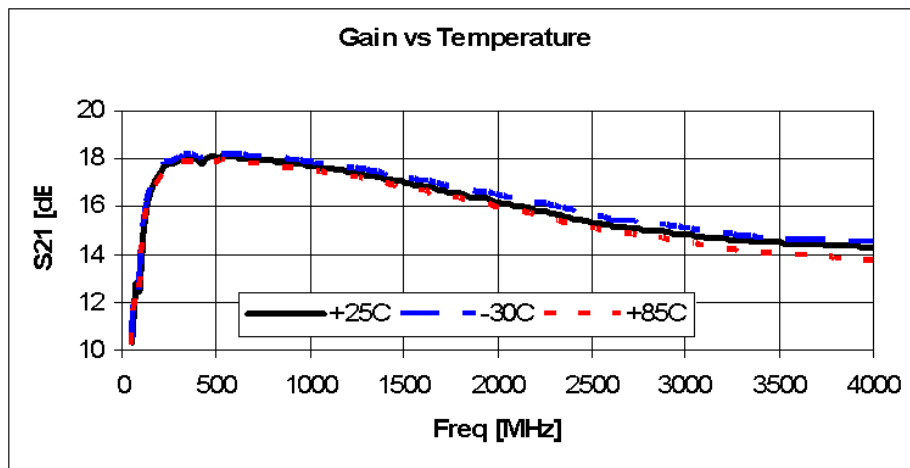
**900MHz, 5V/55mA**

**1900 MHz, 5V/55mA**

**OIP3**

**ACPR**

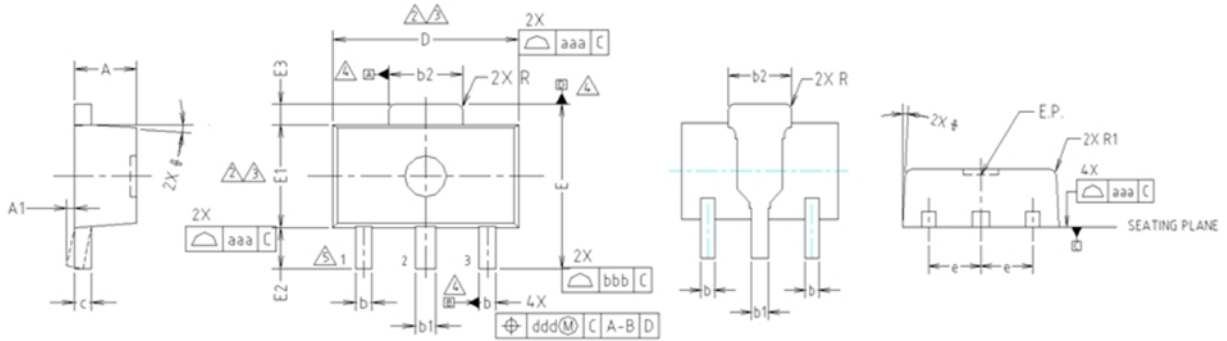
**Gain Flatness**

### Package Outline Dimension



- NOTE:**  
 1. DIMENSIONS IN MILLIMETERS.
- ⚠ DIMENSION D DOES NOT INCLUDE MOLD FLASH, PROTRUSIONS OR GATE BURRS. MOLD FLASH, PROTRUSIONS OR GATE BURRS SHALL NOT EXCEED 0.5mm PER END. DIMENSION E1 DOES NOT INCLUDE INTERLEAD FLASH OR PROTRUSION. INTERLEAD FLASH OR PROTRUSION SHALL NOT EXCEED 0.5mm PER SIDE.
  - ⚠ DIMENSIONS D AND E1 ARE DETERMINED AT THE OUTMOST EXTREMES OF THE PLASTIC BODY EXCLUSIVE OF MOLD FLASH, TIE BAR BURRS, GATE BURRS AND INTERLEAD FLASH, BUT INCLUDING ANY MISMATCH BETWEEN THE TOP AND BOTTOM OF THE PLASTIC BODY.
  - ⚠ DATUMS A, B AND D TO BE DETERMINED 0.18mm FROM THE LEAD TIP.
  - ⚠ TERMINAL NUMBERS ARE SHOWN FOR REFERENCE ONLY.

SYMBOL	MILLIMETERS			NOTE
	MINIMUM	NOMINAL	MAXIMUM	
A	1.40	1.50	1.60	
A1	0.00	—	0.10	
b	0.38	0.42	0.48	
b1	0.48	0.52	0.58	
b2	1.79	1.82	1.87	
c	0.40	0.42	0.46	
D	4.40	4.50	4.70	2,3
E	3.70	4.00	4.30	
E1	2.40	2.50	2.70	2,3
E2	0.80	1.00	1.20	
E3	0.40	0.50	0.60	
e	1.50 TYP.			
φ	4° TYP.			
R	0.15 TYP.			
R1	—	—	0.20	
SYMBOL	TOLERANCES OF FORM AND POSITION		NOTE	
aaa	0.15			
bbb	0.20			
ccc	0.10			
ddd	0.10			

### Suggested PCB Land Pattern and PAD Layout

**PCB Land Pattern**

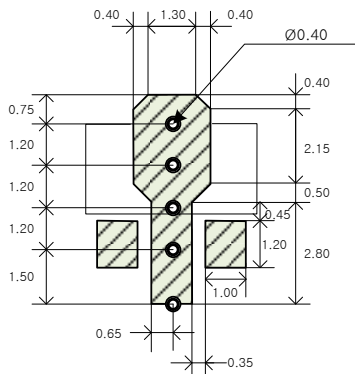

Note : All dimension \_ millimeters

PCB lay out \_ on BeRex website

**PCB Mounting**

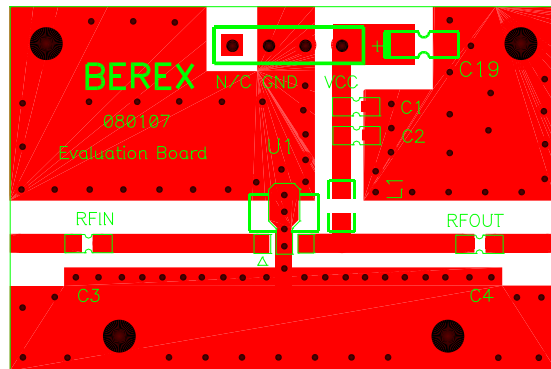



### Package Marking

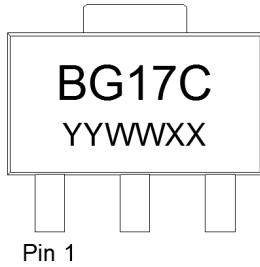

YY = Year, WW = Working Week,  
XX = Wafer No.

### Tape & Reel

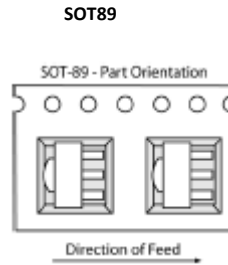

Packaging information:

- Tape Width (mm): 12
- Reel Size (inches): 7
- Device Cavity Pitch (mm): 8
- Devices Per Reel: 1000

### Lead plating finish

100% Tin Matte finish

(All BeRex products undergoes a 1 hour, 150 degree C, Anneal bake to eliminate thin whisker growth concerns.)

### MSL / ESD Rating

<b>ESD Rating:</b>	Class 2
<b>Value:</b>	<b>Passes &lt;4000V</b>
<b>Test:</b>	Human Body Model (HBM)
<b>Standard:</b>	JEDEC Standard JESD22-A114
<b>MSL Rating:</b>	<b>Level 1 at +265°C convection reflow</b>
<b>Standard:</b>	JEDEC Standard J-STD-020



Proper ESD procedures should be followed when handling this device.

### NATO CAGE code:

2	N	9	6	F
---	---	---	---	---